

# Haloview

---

## 2.4G Digital 1080P 7" Touch Screen Tire Pressure Monitoring Backup Camera System

### User Manual



## Byte Tango 7 TPMS

### BT7 TPMS

V1.1

Please read all instructions carefully before using, and keep the manual for future reference.

# CONTENTS

<b>1. Precautions</b>	<b>1</b>
<b>2. Product introduction</b>	<b>4</b>
<b>3. Features</b>	<b>5</b>
<b>4. Specifications</b>	<b>5</b>
<b>5. Functions Of Each Part</b>	<b>6</b>
<b>6. Basic Operation</b>	<b>7</b>
<b>7. Wiring Instruction</b>	<b>9</b>
<b>8. Installation</b>	<b>10</b>
<b>9. MENU</b>	
Shortcut Menu	12
9.1 MENU	14
9.2 VOLUME	14
9.3 PAIRING	14
9.4 PICTURE	16
9.5 MIRROR	16
9.6 QMODE	16
9.7 SETTING	17
9.8 SCAN	17
9.9 PARK-LINE	18
9.10 RECORD	18
9.11 PLAY	19
9.12 Trigger Function	20
<b>10. TPMS Icons Introduction</b>	<b>21</b>
<b>11. Installation</b>	<b>23</b>
<b>12. TPMS Meun</b>	
12.1 Access to TPMS MENU	25
12.2 Auto learn	25
12.3 Manual ID	27
12.4 Setting the high and low pressure values of the axis	27
12.5 Set HIGH TEMP Value	28
12.6 Sensor Setting for T1 T2 T3	29
12.7 Delete ID	29
12.8 Reset and Del All IDs	29
12.9 Connect or Disconnect Trailer	29
12.10 Buzzer Sound Adjustment	30
<b>13. TPMS Quick Setting</b>	<b>30</b>
<b>14. Baseline Tire Pressure and Tire Safety</b>	
Potential causes of signal loss	34
Sensor Specification	34
Booster Specification	34
<b>15. Troubleshooting</b>	<b>35</b>

## 1 Precautions

### ● Storage

1. Do not expose the monitor to extreme heat, cold, or sudden temperature changes. The storage temperature of this device is -30 to +80°C or -22 to +176°F. The operating temperature is -20 to +70°C or -4 to 158°F with the humidity under RH90%.
2. Never use this device in environments with excessive moisture, dust or smoke.
3. Avoid dropping or striking this device.
4. Never puncture, scratch or use abrasive cleaning materials on this device.
5. Leave at least a 2" space between the monitor and walls, cabinets or other objects to allow adequate air circulation around the device.
6. The monitor is not designed to be waterproof.

### ● Operating Precautions

1. The device can be powered by DC 10-32V or USB Type-C 5V/2A.
2. Improper cable connections may damage the monitor. Remove the power cable connections when you do not intend to use the device.

### Warning

1. High voltage is present within the monitor. The opening of the case should be by professionals.
2. Do not watch the video while driving unless you are monitoring the rear view camera display.

### Special Notice

Occasionally, a few highlights or dark spots may occur on the LCD screen. This is a very common phenomenon in active matrix display technology, and doesn't necessarily indicate any defects or faults. Never try to repair this device by yourself. In case of any problems, please turn off the display at once and notify our company or authorized dealer. The monitor is a complex device. Any disassembly or modification may lead to damage and void the warrantee.

### ● Maintenance

1. Remove all the cable connections from the monitor before cleaning the device.
2. Use a mild household detergent and clean the unit with a slightly damp, soft cloth. Never use strong solvents such as thinner or benzine, as they might damage the finish of the device.



# CAUTION



**RISK OF ELECTRIC SHOCK  
DO NOT OPEN**

**CAUTION: TO REDUCE THE RISK OF ELECTRIC SHOCK  
DO NOT REMOVE COVER(OR BACK).  
NO USER-SERVICEABLE PARTS INSIDE.  
REFER SERVICING TO QUALIFIED SERVICE PERSONNEL**



This symbol is intended to alert the user to the presence of uninsulated "dangerous voltage" within the product's enclosure that may be of sufficient magnitude to constitute risk of electric shock to persons.



This symbol is intended to alert the user to the presence of important operating and maintenance (servicing) instructions in the literature accompanying the appliance.

## FCC WARNING

This device complies with part 15 of the FCC Rules.

Operation is subject to the following two conditions:

(1) this device may not cause harmful interference, and (2) this device must accept any interference received, including interference that may cause undesired operation. Any changes or modifications not expressly approved by the party responsible for compliance could void the user's authority to operate the equipment.

**NOTE:** This equipment has been tested and found to comply with the limits for a Class B digital device, pursuant to Part 15 of the FCC Rules. These limits are designed to provide reasonable protection against harmful interference in a residential installation. This equipment generates, uses and can radiate radio frequency energy and, if not installed and used in accordance with the instructions, may cause harmful interference to radio communications. However, there is no guarantee that interference will not occur in a particular installation.

If this equipment does cause harmful interference to radio or television reception, which can be determined by turning the equipment off and on, the user is encouraged to try to correct the interference by one or more of the following measures:

- Reorient or relocate the receiving antenna.
- Increase the separation between the equipment and receiver.
- Connect the equipment into an outlet on a circuit different from that to which the receiver is connected.
- Consult the dealer or an experienced radio/TV technician for help.

To maintain compliance with FCC's RF Exposure guidelines, This equipment should be installed and operated with minimum distance between 20cm the radiator your body: Use only the supplied antenna.

## 2 Product Introduction

Haloview Tire Pressure Monitoring System, combines 2.4GHz 1080P wireless rear view system with external wireless tire pressure monitoring system. While taking into account the rear view monitoring, it can monitor the pressure and temperature of the vehicle tires, and support different levels of warnings, including pressure changes (too low, too high, air leakage), high temperature, signal loss, and so on. This system can be switched among 3 different vehicles and up to 32 tires can be monitored.



**Haloview Tire Pressure Monitoring Monitor**  
(Simultaneously supports 4 wireless 1080P cameras)



**Camera**



**Haloview Cap Sensor**



**Haloview Signal Booster**



**Suction Cup Mount Bracket**



**3M Mount Bracket**



**Cigarette Lighter**



**Type-C Cable**



**Camera Conversion Cable**



**Power Adapter for Pre-wired RV**



**Pairing Cable**

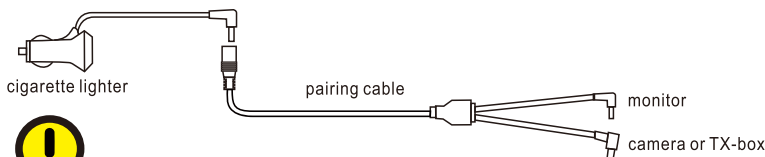

Please pair the camera with the monitor by using external 12V power supply and provided Pairing Cable before installing this system on your RV.

The product is under continuous improvement and the specifications will change without notice. Picture for reference only. Please refer to the actual product and accessories.

### **⚠ Special Notice**

Accessories supplied in kit may be different for each application.

### 3 Features

1. Combination of 1080P touch screen wireless backup camera system with wireless tire pressure monitoring system.
2. NORMAL, MIRROR, FLIP and MIR-FLIP viewing available.
3. Split mode auto-scan mode and single-display mode available.
4. Support 4-channel composite and single-channel recording in AVI signal format.
5. Auto dim function available.
6. 4 wireless camera inputs.
7. Video input:1080P.
8. Wide voltage input: DC10-32V or USB Type-C 5V.
9. Camera night LED can be turned ON/OFF via monitor.
10. Up to 32 sensors supported.
11. External signal booster ensures stable and reliable signal transmission.

### 4 Specifications

LCD size	7" 16:9
Resolution	1024x3(RGB)x600
Contrast	800:1
Brightness	1000 cd/m <sup>2</sup>
Viewing Angle	U/D:85,R/L: 85
Aspect Ratio	16:9
Channel	4 Channel
Operating Frequency	2400-2483 MHZ
Receiving Sensitivity	-85 dBm
Latency	120ms
Transmitting Distance	984ft line of sight
Micro-SD /TF Card	Max.256G
Video Format	AVI
Power Supply	DC10-32V USB and Type-C 5V
Power Consumption	Max.6W
Loudspeaker	1W/8Ω
Operating temperature	-20~+70°C,RH90%
Storage temperature	-30~+80°C,RH90%

## 5 Functions of each part

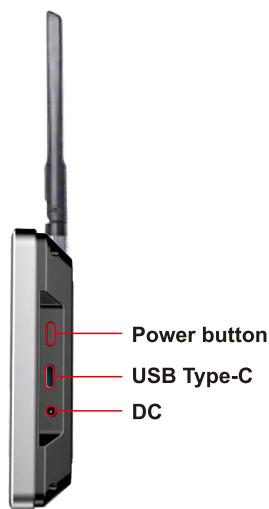
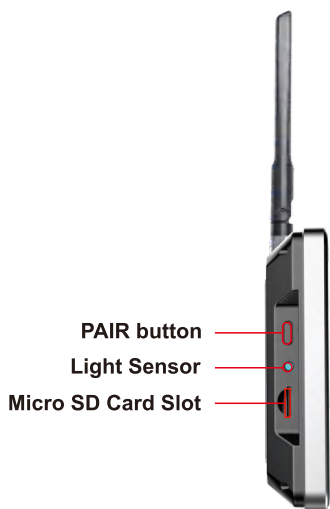

### Power Indicator

It turns to red when the monitor is powered on.



### Speaker

## 6 Basic Operation

### Installation of Suction Cup Mount:

1. Adjust monitor height by sliding monitor up or down in slot, then tighten knob.  
Adjust monitor angle by loosening lower knob on suction cup mount, tilting monitor to desired angle and re-tighten knob.

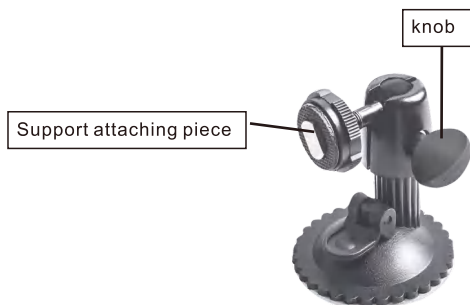

### 2. Installation of 3M Mount

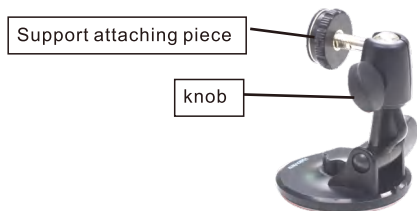

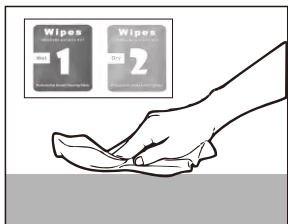

1. Clean the place where you plan to install the mount by provided alcohol wipes.

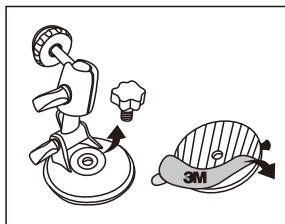

2. Remove the base from the mount and paste the base on that place.

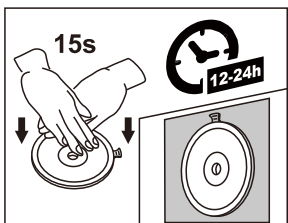

3. Press the adhesive base firmly for 15 seconds when pasting. The base needs to be left to stand for 12-24 hours before hanging the monitor.

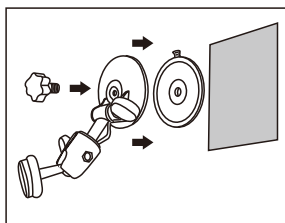

4. Attach the mount to the base.

**This multi-purpose multi-angle adjustment display mount can be used like below**

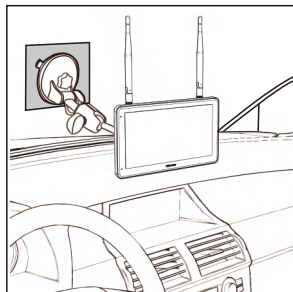
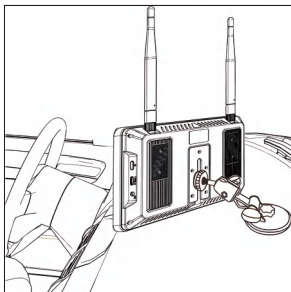
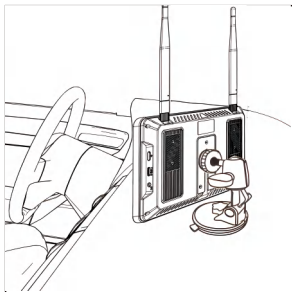

**Please put static sticker on the windshield before mounting the bracket on the front windshield.**

## 7 Wiring Instruction

### Camera Wiring Method 1: (Suggested)

Power on the camera by connecting the Red positive wire to 10 - 32 VDC power source, Black to Negative/Ground source, and connecting camera plug.

**PLEASE MAKE SURE GREEN WIRES UNCONNECTED**

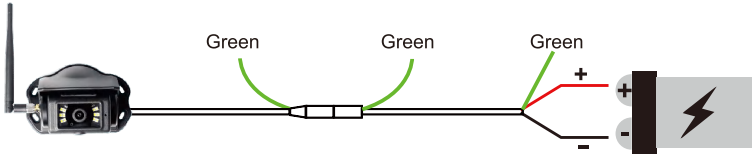

### Camera Wiring Method 2:

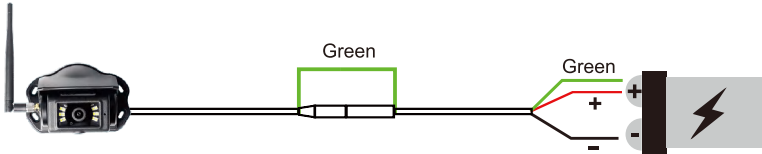

**Notice:** Touch Screen invalid when triggering function activated. If you use the camera for long-hour observation, please do not follow Camera Wiring Method 2.

Connecting the camera plug and Green wires. Connecting the red and green wire to 10-32VDC power source, connect the Black wire to Negative/Ground source.

This wiring method can achieve camera triggering function. For example, if the green wire is connected to left turn signal light, the monitor will switch to this camera every time the left turn signal light is turned on. For multi cameras, triggering function can help switch screen display automatically without manually switching channels of cameras to avoid diverting the driver's attention during driving.

### Monitor Wiring:

Connect the monitor to the cigarette lighter power adapter.  
Power the monitor through the vehicle's 12V cigarette lighter or USB Type-C.



For more cameras, extra cameras can be paired separately to CAM1/CAM2/CAM3/CAM4. Please refer to page 14 PAIRING.

## 8 Installation

### Please find best signal reception position before installation

The metal body of the vehicle can attenuate wireless signal strength sharply. It is necessary to test the signal strength before installation.

- ① Please connect monitor and camera as below picture



- ② Pairing the camera to the monitor, please refer to page 14 PAIRING. 4 cameras can be paired separately to CAM1/CAM2/CAM3/CAM4.
- ③ Put the monitor and the camera at the intended position to test signal strength.

### Antenna

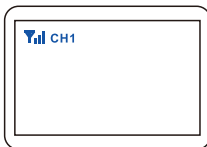
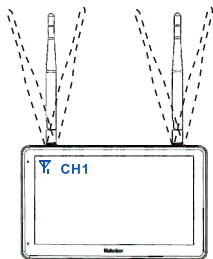

**Good signal**



**Poor signal**

If you get poor signal reception, or signal cannot reach at least 2 bars, please keep the antennas perpendicular and adjust the angle of antenna to find best signal reception position.

If signal strength of the position that you planned to install a camera is under 2 bars, please change to another position, or mount the camera higher to make sure the antenna highest of the top without being blocked. Please refer to below pictures:



**Installation Position 1:** Mount the camera higher than your vehicle's roof, keeping the antenna vertical.

**Installation Position 2:** Mount the camera lower but as close as possible to vehicle's roof, and move the antenna outward **15-30 degree**. The antennas proximity to any metal surfaces on the vehicle may affect signal strength.

### **Special Notice**

After position adjustment, you can start installation if your signal strength is still above 2 bars.

Image freezing may occur when the vehicle is **42-65ft** long and the antenna is mounted in a poor location (the antenna is not placed on the roof of the vehicle or there is obstruction around the antenna). In this case, it is recommended to purchase the Haloviev **10M** or **12M** antenna extension cable and place it on the roof without any obstacles.

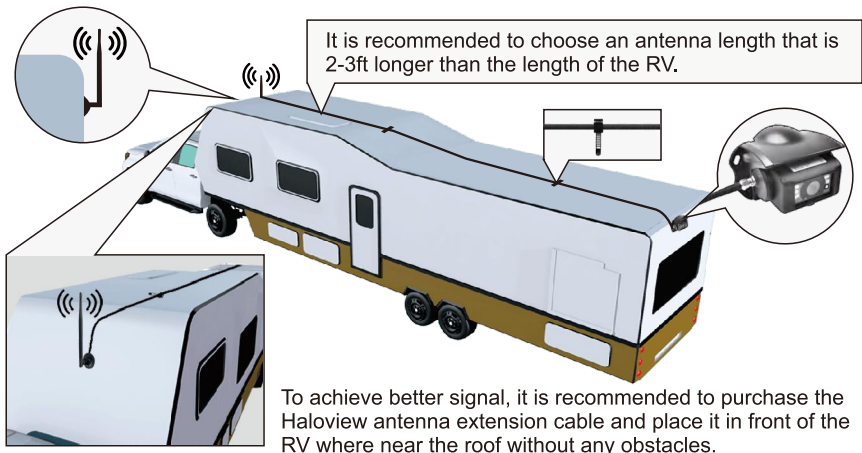

## Shortcut Menu

Tap the screen when in single image mode, it pops-up the first group of shortcut MENU. You can easily switch to each of the four channels of cameras or go to Quad Mode.

Tap  to go to Main MENU.





Tap the screen again, it pops-up the second group of shortcut MENU.



Tap  to turn on/off parking line in current channel of camera. When parking line is turned on, exit the shortcut menu to display the parking line.

Tap  to turn on/off voice in current channel of camera.

Tap  to adjust the screen brightness.

Tap  to turn on/off current camera night light. When camera night light is turned on, the indicator will turn from  to .

Tap  to start recording or pause recording.

Tap  to enter tire pressure monitoring MENU.

In quad mode (QMODE), an audio icon highlighted in CH1 that has the audio active.

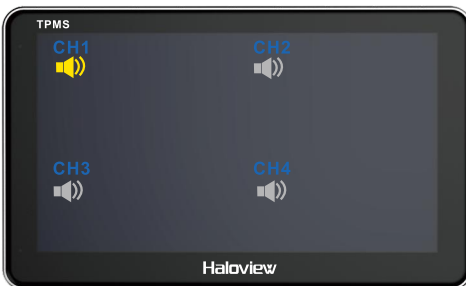

Tap any of the audio icon to hear the audio of any channels of cameras.

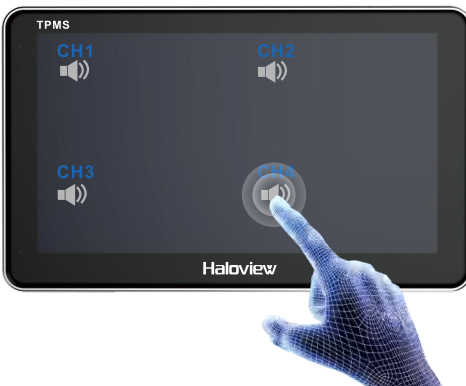

The audio icon is highlighted to indicate that audio is turned on for that channel.

**Notice:** Please tap the audio icon instead of other areas. Otherwise the display will switch to the certain channel of camera.

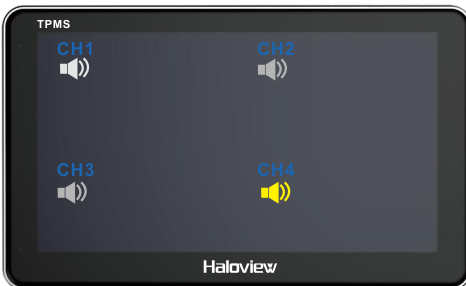

## 9.1 MENU



Press  to go to Main Menu

Press  to exit.

## 9.2 VOLUME



Tap  to get access to VOLUNE setting

Tap the bar to adjust volume. Tap ON/OFF to MUTE or UNMUTE the volume.

## 9.3 PAIRING



Camera and monitor are paired at the channel of CAM4 as factory default setting. When you open the box, power on the monitor and camera, tap the monitor to find the first group of shortcut Menu and tap CH4, the image will be displayed. Otherwise, please try below methods for pairing.

Tap  to get access to Main Menu. Tap  to enter pairing status, you will have 50 seconds for pairing. Press the pairing button on the bottom of the camera until you hear a "tah". Video will be displayed after pairing complete.



Quick Access to Pairing Status:  
Press the PAIR button for 3 seconds to enter pairing status.





If you press the pair button by mistake and the monitor enters the pairing status, you can tap  to exit the pairing status.





## 9.4 PICTURE



Tap  to get access to Main Menu. Tap  to enter Picture setting. Tap the bars to adjust BRIGHTNESS/CONTRAST/COLOR. Tap ON/OFF to turn on/off the current camera night led light.



## 9.5 MIRROR

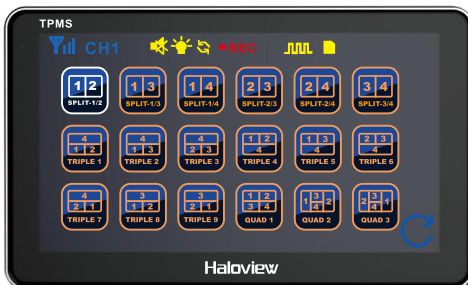

Tap  to get access to Main Menu. Tap  to enter MIRROR setting. Tap Normal/Mirror/Mir-flip/Flip at your will.

## 9.6 QMODE



Tap  to get access to Main Menu. Tap  to enter QMODE setting. Tap any of desired display mode.

## 9.7 SETTING



Tap  to get access to Main Menu. Tap  to enter.  
Tap ON/OFF to turn on/off Trigger.  
Tap NTSC/PAL to switch video format.

VIDEO FORMAT	COUNTRY
<b>PAL</b>	Argentina, Australia, Austria, Belgium, Brazil, Bulgaria, China, Cyprus, Czechoslovakia, Denmark, Dubai, Egypt, Finland, France, Germany, Gibraltar, Greece, Hungary, Iceland, India, Indonesia, Ireland, Israel, Italy, Jordan, Kuwait, Luxembourg, Malaysia, Netherlands, New Zealand, Norway, Sultanate of Oman, Poland, Portugal, San Marino, Saudi Arabia, Singapore, Spain, Sweden, Switzerland, Turkey, United Kingdom,
<b>NTSC</b>	Bolivia, Canada, Chile, Colombia, Costa Rica, Ecuador, Japan, South Korea, Mexico, United States

Tap ON/OFF to turn on/off Autodim. When Autodim is turned on, monitor will automatically decrease brightness in low light.

Tap the bar from 0 to 45 to set screen off duration. If 0 is selected, the screen stays on. If 45 is selected, the display will turn off after 45 seconds of inactivity.

## 9.8 SCAN



Tap  to get access to Main Menu. Tap  to enter SCAN setting.  
The SCAN function allows the monitor to automatically switch channels of cameras.

## 9.9 PARK-LINE

Tap  to get access to Main Menu. Tap  to enter parking line setting.  
You can slide the screen to adjust the inclination and the width of the parking line.

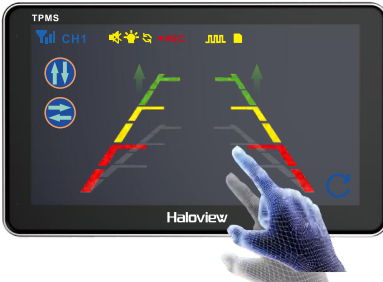

Slide up/down to adjust park lines vertically. Slide left/right to adjust park lines horizontally.

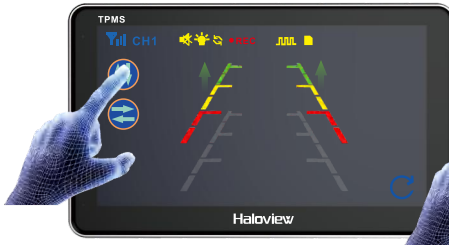



Hold the  icon to quickly slide park-line vertically.

Hold the  icon to quickly slide park-line horizontally.

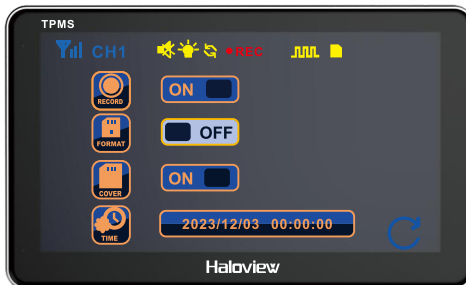
## 9.10 RECORD



Tap  to get access to Main Menu. Tap  to enter RECORD setting. Please insert TF card in TF card slot, max 256G Micro SD card.

**Note:** TF card must be formatted before using. Tap Format ON and Confirm Format. After TF card is formatted, a yellow folder icon will be shown on the screen, indicating TF card is available now.

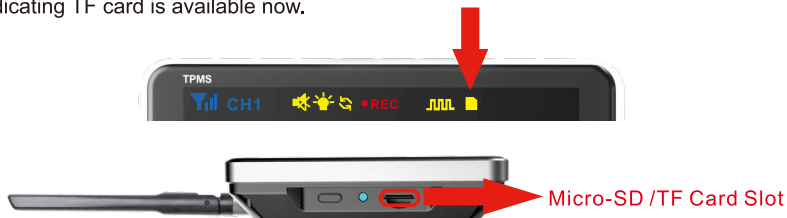

When COVER is turned on, overwrite function will be activated. Previously recorded video files will be overwritten when TF card memory is full.

**Note:** When in QUAD or SPLIT display, the monitor will record all displayed channel of CAM at the same time.

### TIME Setting:

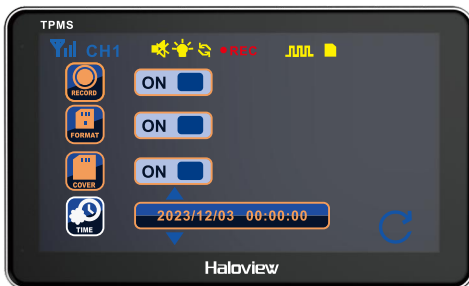

Tap Year/Month/Date/Hour/Minute/Second, it will pop-up  and , tap  and  to adjust Year/Month/Date/Hour/Minute/Second.

### 9.11 PLAY

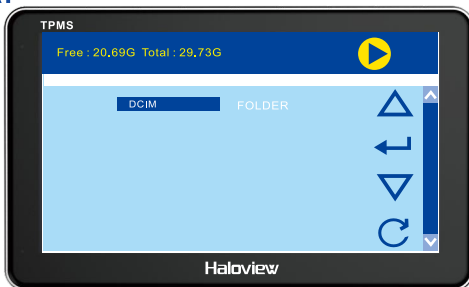

Tap  to get access to Main Menu. Tap  to enter PLAY setting.

Tap  to select, Tap  and  to move up or down.

Tap  to play the selected file.

Read the SD card through PC, there will be two formats of files.  
It is suggested to play the AVI format file for higher video resolution.

## 9.12 Trigger Function

Tap  to get access to  The Trigger switch off by default.













Tap ON to activate Trigger function. If trigger switch is turned on, the yellow icon  will appear on display. To achieve trigger function, you also need to complete trigger wiring.



In Triggering status, MENU operation invalid, and the screen prompts TRIGGER LOCK.



## 10 TPMS Icons Introduction

	Tire pressure sensor icon gray (unlearned ID).
	Tire pressure sensor icon blue (learned ID)
	Sensor selected (yellow frame)
	Sensor alarm (red frame)
	Tap PSI or BAR to switch barometric pressure unit. Tap °F or °C to switch temperature units
	Yellow Alert Icon: low battery of any of the sensors. Note: The sensor low battery alarm only displays a warning icon without warning tone.
	Red Alert Icon: Tire Pressure Warning, including High Pressure, Low Pressure, Fast Pressure leakage, Slow Pressure leakage, Sensor Loss.
	High Pressure Alert
	Low Pressure Alert
	High Temperature Alert
	Low Battery Alert



High Pressure Alert



Low Pressure Alert

When any one or more sensors prompt alarm, tap that sensor to check detailed alarm information.



Slow Leak Alert



Fast Leak Alert

When any one or more sensors prompt alarm, tap that sensor to check detailed alarm information.



Sensor Loss Alert



Low Battery Alert

When any one or more sensors prompt alarm, tap that sensor to check detailed alarm information.

**LOSS**

Sensor Loss Alert

**SLOW LEAK**

Tire pressure drops greater than 6 PSI in 2 to 10 minutes

**FAST LEAK**

Tire pressure drop greater than 3 PSI in 2 minutes



High Temperature Alert.

When any one or more sensors prompt alarm, tap that sensor to check detailed alarm information.

If there is a high temperature alert, please get off the road and figure out the cause of the tire overheating. In most cases, it is caused by stuck calipers or overheated bearings.



The Booster green light ON indicates it is working.



The Booster blue light blinks, indicating it has received data from the sensor and forwarded it successfully.

## 11 Installation

11.1 The external Booster compliance with IP68 waterproof standard, the best recommended mounting location is on the chassis. For motorhomes and buses, the Booster must be located on the rear axle or chassis at position A. If the signal is not good, a second Booster should be added at position B inside the cab.

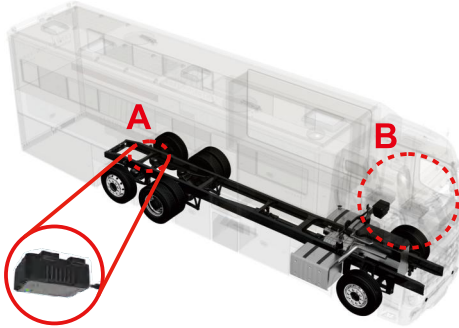

11.2 For trailers, preferably place the Booster on the front towing pin or on the chassis at position B. If the signal is not good, a second Booster should be added on the rear axle at chassis position A.

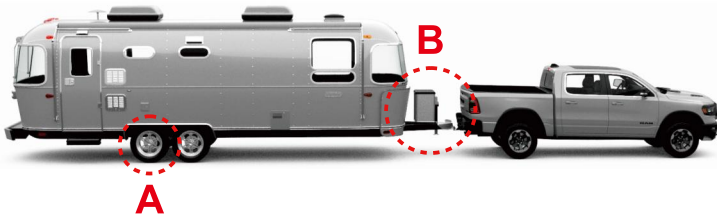

Once the mounting location has been determined, connect the Booster's red (positive: +) and black (negative: -) wires to vehicle 12V or 24V DC power supply. Please make sure that the wire connections and terminals must be sealed and waterproof. Please secure the Booster as firmly as possible to minimize vibration. You can use the supplied wiring harness to secure the Booster and wires.



### 11.3 Cap Sensor Installation

a) After the BOOSTER is installed, unscrew the cap of the sensor and put in the CR1632 coin cell. Note that the (+) sign of the coin cell is facing up.



b) Screw the anti-theft nut onto the threads of the valve head to the end. The anti-theft nut is not required but is supplied as an anti-theft device.

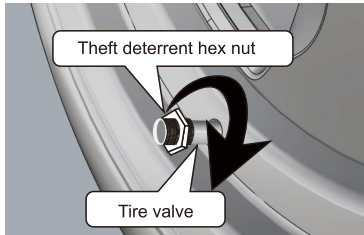

c) Screw the correctly marked sensor onto the valve for the tire. Tighten the sensor until air stops leaking and the sensor bottoms out on the valve. Then tighten another quarter turn to hold it in place. Do not over-tighten.

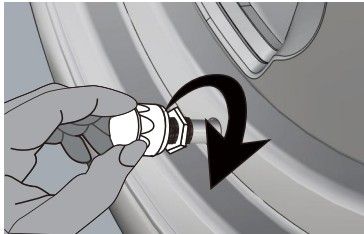

d) Using the wrench provided, tighten the anti-theft nut to the bottom of the sensor to prevent the sensor from being removed. Keep the wrench for future use.

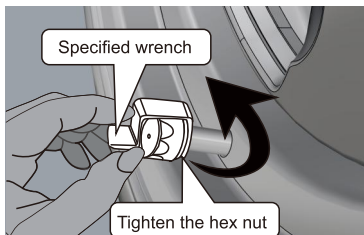

e) To inflate or deflate the tire, the cap sensor must be removed.

## 12 TPMS Menu

### 12.1 Access to TPMS MENU

Tap shortcut  to enter TPMS MENU

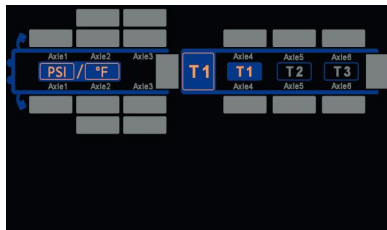
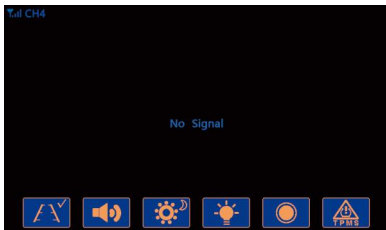

Entering TPMS MENU when an alert prompts

If the tire pressure alarm icon  appears on the screen, you can directly tap the alarm icon to enter the TPMS MENU.

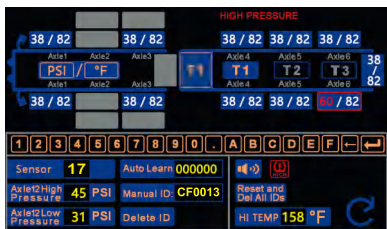

### 12.2 Auto learn

The monitor can be powered by power bank via Type-C cable, which makes it easier to operate the monitor close to the tires for Sensor ID auto-learning.





Tap the sensor icon, e.g. sensor1, and then tap Auto Learn, it will indicate Waiting...

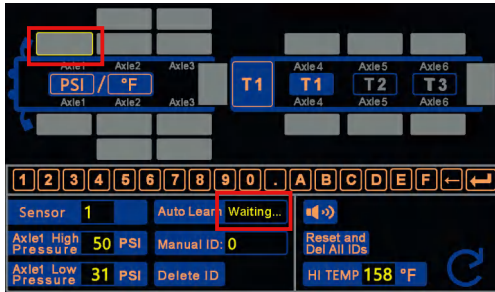

Screw a sensor onto the tire in 15 seconds and the display will change from Waiting... to sensor ID number. For example: CF0013. After successful auto learning, the sensor icon will change from gray to blue, its pressure and temperature will appear, such as the following: 37/82, where 37 corresponds to PSI and 82 corresponds to °F .

Tap  to switch pressure and temperature unit to BAR/°C.

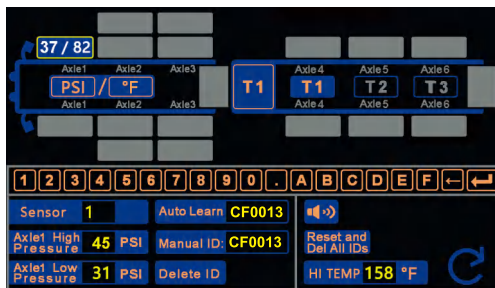

## 12.3 Manual ID

Manually enter the sensor ID, which is printed on the top of the sensor cap.



Tap Manual ID, enter the 6 character ID number by keypad and tap  to confirm.

For example, Sensor 1 in the following figure:

After Manual ID, please screw the sensor on valve, after that, the sensor will first appear as -/-. After data received, the sensor data will appear on the display, e.g. 37 / 82.

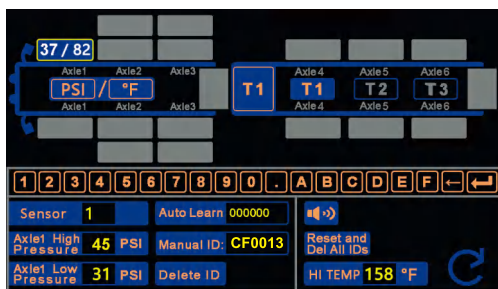

Learn all the tire sensors by following the Auto Learn or Manual ID steps.

Do not perform manual ID if you've already operated auto-learn ID.

## 12.4 Setting the high and low pressure values of the axis

When Auto Learn is applied, the High Pressure value is automatically set 120% of current tire pressure value. The value can be modified manually by keypad.

a) To change the value, tap the value in the yellow High Pressure box.



b) Modify the value by using keypad.



c) Tap enter to confirm. 

If a value is entered incorrectly, it can be deleted by tapping the backspace key. 

**Note:** The High Pressure box does not support English letters.

Once High Pressure is modified manually, the High Pressure values of other sensors in the same axis will be modified simultaneously.

## Axle1 Low Pressure

When Auto Learn is applied, the Low Pressure value is automatically set 85% of current tire pressure value.

The value can be modified manually by keypad.

Once Low Pressure is modified manually, the Low Pressure values of other sensors in the same axis will be modified simultaneously.

If the current sensor pressure is higher than the set High Pressure value or lower than the set Low Pressure value, an alarm icon will be displayed at the top of the screen with a red circle indicating the location of the alarmed tire. In addition, the monitor buzzer will sound an alarm tone. If more than one alarm occurs, tap the sensor to check it out.

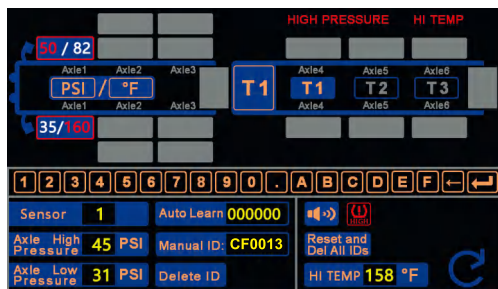

## 12.5 Set HIGH TEMP Value

a) Tap the HIGH TEMP box, it turns to yellow. 

b) Modify the value by using keypad. 

c) Tap enter to confirm. 

If a value is entered incorrectly, it can be deleted by tapping the backspace key. 

The HI TEMP numerical unit that can be switched by Tapping .

Once the unit of HI TEMP is switched, the HI TEMP of all sensors will be synchronized to change to the same unit.

## 12.6 Sensor Setting for T1 T2 T3

Tap **T1** to switch among T1, T2 and T3.

As shown in the following figure, it has been switched to T1 and sensor 17 has been selected.

If the towing vehicle drives away from the trailer, please disconnect that trailer on TPMS MENU, otherwise the system will keep prompting the Sensor Loss Alert.

Tap it to switch among T1/T2/T3.



T1 highlighted indicates T1 is connected.

T2/T3 gray background indicates T2/T3 is disconnected.

## 12.7 Delete ID

If a sensor is learned with an unrelated trailer, you can delete the sensor information by Delete ID. After selecting the sensor, tap Delete ID and confirm YES to delete the sensor information at the current location.



## 12.8 Reset and Del All IDs

Tap Reset and Del All IDs and then tap YES, the system will reset all parameters set in the Tire Pressure MENU and will also delete all sensor IDs.



When to operate Reset and Del All IDs

1. If the sensor is learned to wrong position.
2. If some major changes made on your vehicle, or you need to change some tires.

## 12.9 Connect or Disconnect Trailer

The system supports connecting or disconnecting three different trailers.

Tap T1\T2\T3 to connect or disconnect **T1** **T2** **T3**

If T1 disconnected, all the sensors learned with T1 will not prompt alert if they trigger alarms.

## 12.10 Buzzer Sound Adjustment

The alarm sound can be adjusted by tapping  on the buzzer icon.

If MUTE is set, the system will not raise alarm sound. A mute icon  will be displayed at the top of the screen after exiting the MENU.



## 13 TPMS Quick Setting

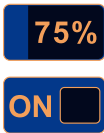

OSD transparency options 100%, 75%, 50%.

Turn ON/OFF TPMS Preview

When TPMS Preview is turned ON

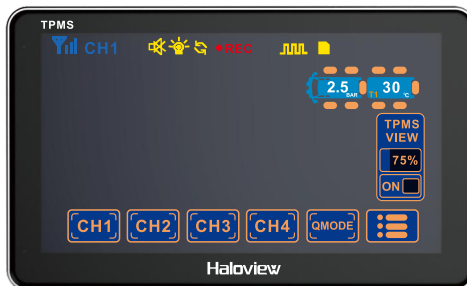

When TPMS Preview is turned ON, there is a quick reading displays at the top right

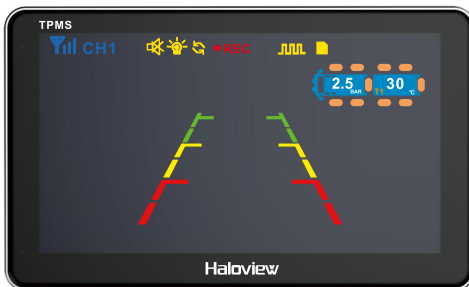

When TPMS Preview is turned OFF

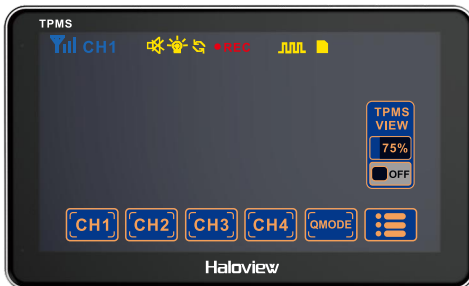

When TPMS Preview is turned OFF, quick reading disappears.

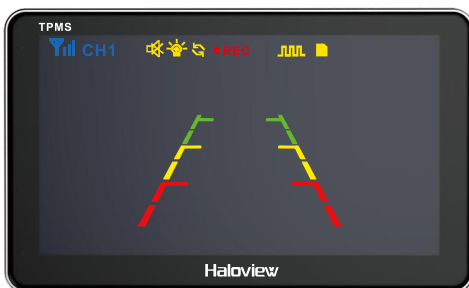

When Sensors are not coded, TPMS Preview displays only the blue coach.



When Sensors are coded, orange tires are displayed.



After sensors coded, the tire pressure values for each tire are displayed in turn.

The currently displayed tire pressure value belongs to the tire whose icon is currently blinking. Tire pressure value contains two data, the first data is the tire pressure, the second data is the tire temperature.

Tire Pressure: 2.5 BAR  
Tire Temperature: 30 °C

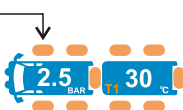

Tire Pressure: 2.7 BAR  
Tire Temperature: 28 °C



When an abnormality occurs, that tire icon turns from orange to red and a tire pressure warning symbol appears below. For example if a tire triggered low pressure alert, a  symbol appears under that tire, and alert sound beeps. Click alert icon to cancel the sound. Tire icon remains red even if the alarm tone is deactivated.



Tap  to quickly access the Tire Pressure screen.



## 14 Baseline Tire Pressure and Tire Safety

The baseline tire pressure is the cold tire pressure. In other words, it is the tire pressure before the tire starts rolling on the road.

When we go to Tire Pressure MENU to Auto Learn the sensors, it is recommended to operate under cold tire pressure. In this way, the High and Low pressures value automatically set are more accurate.

**There are two places where you can find out your baseline tire pressure.**

A) A permanently installed nameplate will contain maximum tire pressure, maximum load information, etc. This nameplate can be found on the driver's side door pillar of most vehicles.

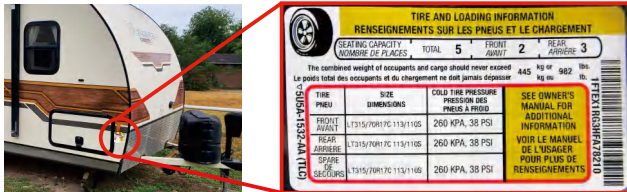

B) On the tire. It is very important that the cold tire pressure cannot exceed the maximum tire pressure indicated on the tire.

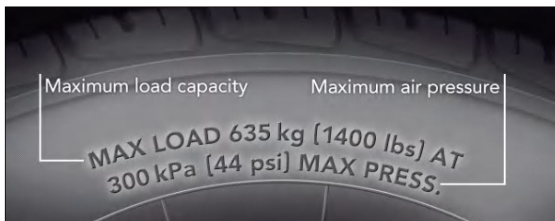

Another important factor in tire safety is weight. Tire pressure is greatly affected by weight. For different load ratings, such as E, G, etc., tire pressure may increase more rapidly with the load rating. If you notice that tire pressure is increasing rapidly, it is recommended to weigh your vehicle and double check the maximum load indicated on the tires. It is also important to understand that even if your vehicle is under the maximum load, the load may not be evenly distributed. For example, if a tandem-axle travel trailer has a maximum tire load of 1,400 pounds and the total loaded weight of the travel trailer is 1,200 pounds, it's still possible that individual tires could be overloaded, depending on how the load is distributed.

A great resource for understanding tire inflation and loads is your tire manufacturer. Every tire manufacturer offers load and inflation charts for ST (specialty trailer), LT (light truck), HD (heavy truck) or RV tires on their website.

The best way to determine what tire pressure to run is to have a professional weigh your vehicle. There are many excellent resources that offer this service, such as RVSEF ([www.RVSafety.com](http://www.RVSafety.com)) and Escapees RV Club ([www.escapees.com](http://www.escapees.com)).

## Potential causes of signal loss

- A) External Booster is not working. Please follow the instructions to install the EXTERNAL Booster. Make sure the Booster is properly connected and the green LED is lit.
- B) The system has been in continuous use for more than 9 months, the sensor batteries may need to be replaced.
- C) The sensor is missing or damaged.
- D) Electronic Interference: With the increasing availability of new wireless products, the tire pressure system signal may be affected by electronic interference. Electronic interference may result in signal intermittent. Booster can solve most interference problems. If you have installed the Booster and the Booster is working properly, consider moving the Booster closer to the monitor.
- E) Distance: Under normal operating conditions, distance is not an issue if you have an external BOOSTER installed. However, extreme cold and low sensor battery (below 2.7V) will shorten the operating distance even with an external Booster installed!
- F) Signal Loss: If the trailer is separated from the tow vehicle and the tow vehicle is driven out of sensor reception range, manually disconnect the T1/T2/T3 connection, otherwise the device will keep prompting for signal loss.
- G) Signal Loss: The monitor does not receive the sensor signal due to poor signal, or the sensor was stolen, resulting in the monitor not receiving the sensor signal for a long time.

## Sensor Specification

Working Temperature	(-20°C--85°C) -4° F to 185° F
Working Humidity	0-100%
Dimensions	(23 x 21 x 21 mm) .8"x .8" x .9"
Battery Voltage	3.0V DC (CR1632)
Battery Life	1 year
Pressure Range	(0 Bar – 15 Bar) 0 – 218 PSI
Pressure Precision	(±0.1 Bar) ±1.5 PSI
Temperature Precision	(± 3°C) ± 6° F

## Booster Specification

Input Voltage	12/24 VDC
Red & Black hard wire connect	2M
12V Battery Consumption	75mA (sending signal) to 14mA (standby)

<p>The sensor is not able to be auto-learned when I screw it on valve.</p>	<ol style="list-style-type: none"> <li>1. Please tap Waiting... again, and then screw the sensor to the valve again.</li> <li>2. Please check whether battery is installed on the sensor.</li> <li>3. Please check if the battery of sensor is higher than 3.0V.</li> </ol> <p>If you have checked all of them and still can't learn a sensor, please go to Reset and Del All IDs, tap YES, and operate auto learn again.</p>
<p>Why doesn't the system alert me when my tire pressure is too low or too high?</p>	<p>Please check if this Trailer is disconnected in the Tire Pressure MENU.</p>
<p>Why does the system occasionally display a FAST LEAK alert and then quickly return to normal?</p>	<p>If the vehicle encounters road debris, potholes, or bumps while driving, the tire pressure may drop rapidly, which result in the sensor FAST LEAK alarm. If the tire pressure doesn't continue to drop, then you don't need to pay any attention to it.</p>
<p>Why is there no buzzer sound indication when the system has an alarm?</p>	<p>Please check if mute is set.</p>
<p>Why is it that when a sensor prompt alert with buzzer sound, the sound stops when the I tap the sensor ?</p>	<p>When there is a sensor alarm, the buzzer sound prompts the user to go and check the issue. After the user tap he sensor, the system determines that the user has viewed the issue and it will stop buzzing.</p>
<p>Why is it that when I enter a value for High Pressure, it always displays the previous value after I hit enter?</p>	<p>Please check the entered value, if it is lower than the value of Low Pressure, the system will determine the value as invalid.</p>
<p>Why is it that when I enter a value for Low Pressure, it always displays the previous value after I hit enter?</p>	<p>Please check the entered value, if it is higher than the value of High Pressure, the system will determine the value as invalid.</p>
<p>Why does the green light on my Booster keep blinking?</p>	<p>Please check that your power supply is a continuous DC supply, not PWM supply.</p>
<p>SD N/A</p>	<p>SD card is not inserted. Please insert a SD card if you want to record videos.</p>
<p>After replacing the battery, the sensor is not transmitting data?</p>	<p>When replacing the sensor battery, wait 1-2 minutes after removing the old battery before inserting the new one, as the system needs time to reset.</p>

# TIPS

1. Sensors sending data immediately when they are screwing on the tires.
2. After sensors coding, when sensors detects abnormal data (Difference between pre and post values greater than 0.3 bar or 4.35 PSI), the sensors will send data immediately.
3. If the tires re-rotate after over 10 minutes stationary, the sensors will send data immediately when they change from static to dynamic.
4. When sensors are manually unscrewed from the tires, the sensors send data immediately. After then, sensors won't send data if continuous no air pressure is detected.
5. When tires are at rest and there is no abnormal data from the sensors, the tire pressure data will be collected after 4 minutes the monitor is turned on.